

TECHNICAL PARAMETERS

Rated peak force Sine _{pk} /Random ¹ _{RMS} /Shock _{pk} ²	31,500/29,225/94,420 lbf
Frequency range	5 - 3,000 Hz
Main resonance frequency	2,400 Hz
Max. displacement Sine/Random/Shock (Pk-Pk) ³	2.5/2.5/3.0 inch
Max. velocity Sine/Random/Shock	79/79/157 inch/sec
Max. acceleration Sine/Random	200/180 g
Max. acceleration Shock (at payload)	3 ms: 300 g (209.4 lb) 6 ms: 100 g (529.1 lb) 11 ms: 100 g (771.6 lb)
Suspension stiffness	565 lbf/inch
Effective moving mass	116.8 lb
Max. payload	1,345 lb
Magnetic stray field ⁴	< 1.5 mT
Armature diameter	18.9 inch
Required compressed air supply	Min. 600 kPa
Total mass	11,684 lb
Interlocks: Temperature, displacement, water flow rate, overcurrent, compressed air, conduction	

1) Random force according to ISO 5344

2) Theoretical maximum shock value. Depends on payload, amplifier, shock and shock width

3) Impact by moving to static mass and frequency is possible

4) measured at 5.9 in. above armature inserts

For long-term tests, the load must be reduced to 80 %. Continuous operation at maximum load can cause damage.

SCOPE OF DELIVERY, OPTIONS AND FEATURES OF THE SYSTEM

Scope of delivery:

- Vibration exciter S 69440
- Trunnion mount with integrated vibration isolation (AIT)
- Power amplifier
- Field power unit
- Cooling unit with integrated hydraulic unit
- Connection cables (each 32.8 ft)
- Water hoses with self-sealing couplings (each 32.8 ft)
- Hydraulic hoses with self-sealing couplings (each 32.8 ft)
- Cooling blower
- Connection box for blower
- Power cable (32.8 ft) for cooling blower (CEE 63 connector)
- Blower hose ø175 mm (16.4 ft)
- Compressed-air hose NW 7.2 (Standard) (32.8 ft)

Options:

- Different hole pattern of armature (different pitch diameter and/or thread inserts) at customers request
- Thermo barrier (-40°F to +284°F)
- Chamber leadthrough
- Climatic chamber support kit
- Remote control (Software)
- ASM-Mode (Auto-Shutdown-Manager)
- Cable/Hose extension
- Factory acceptance test
- ASG-K - Automatic Rotation System
- ERD-Tool - Extended Remote Diagnostic Tool
- AIT Resonance System
- Low Degauss Kit

Features:

- Vibration isolation < 3 Hz (AIT) (with option AITRS 2-3 Hz)
- Fully automatic pneumatic load compensation
- Low-friction hydrostatic bearing (Dual Bearing)
- AIT fixable
- Automatic centering of the AIT-System and the armature
- Degauss kit to reduce stray magnetic field
- Shaker-water circuit with overpressure
- Automatic permanent monitoring of conduction
- Integrated mains switch and line filter
- Energy-saving-mode
- 4 Sigma peak current
- Made in Germany
- Servicehotline

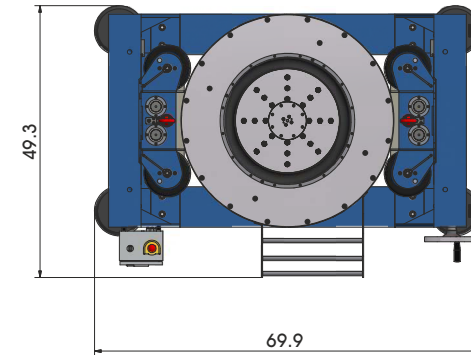
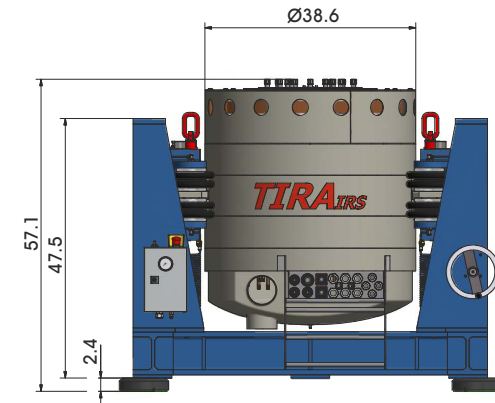

24 Inserts metric M10 or M12 or imperial 3/8-16 or 1/2-13 UNC or UNF

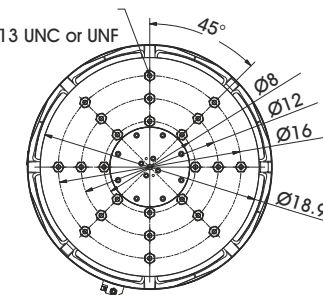

Armature (Standard)

TECHNICAL PARAMETERS Power Amplifier A 6 00 11 402 + Field power supply

Output power _{RMS} ¹	220,000 VA	Interlocks: Overload, Temperature, Displacement, Air supply, Compressed air, Phase monitoring, Emergency stop, Water flow rate, Conductance
Frequency range	DC - 5 kHz	
Voltage _{RMS} ¹ max.	212 V	Features: Mains switch and integrated line filter Low/Mid/High-Field (Energy-saving mode) Field voltage/Field current variable according to customer spec. 4 Sigma peak current Color-Touchscreen
Current _{RMS} ¹ max. ¹	2,000 A	
Signal input voltage _{PK}	±10 V	
Total Harmonic Distortion (at 70A _{RMS} ¹ , 200 Hz)	< 0.2 %	
Signal to noise ratio	> 80 dB	
Power supply - Amplifier (Standard)	3~ / N / PE 480 V±5% 60 Hz Direct connection (Terminal block)	
Power supply - Field power supply (Standard)	3~ / N / PE 480 V±5% 60 Hz Direct connection (Terminal block)	
Max. power consumption at 480 V		
Amplifier (incl. cooling unit)	370 kVA	
Field power supply	40 kVA	
Recommended fuse protection Amplifier (Standard)	500 A slow	
Recommended fuse protection FPS (Standard)	125 A slow	
Dimensions - Amplifier (WxHxD)	126.0 x 86.6 x 35.4 in.	
Dimensions - Field power supply (WxHxD)	23.6 x 68.5 x 33.5 in.	
Total mass - Amplifier	5,952 lb	
Total mass - Field power supply	1,102 lb	

1) Values in connection with vibration exciter S 69440



Amplifier



Field power supply

TECHNICAL PARAMETERS Cooling unit C 59412

Environmental conditions:	
Temperature	41 - 86 °F
Relative humidity	10 - 80 %
Energy transfer	max. 3 kW
Process water:	
Temperature	41 - 59 °F
Volume flow at max. supply temperature	5.9 cfm (for full extension)
Working pressure: supply - static	≤ 116 psi (≤ 800 kPa)
Working pressure: dynamic differential pressure	≥ 43.5 psi (≥ 300 kPa)
Dissipated heat flow	max. 110 kW
Nominal width of supply pipes	R 1 1/2 IT (1.57 in.)
pH value	7 ± 1
Dimensions of dirt particles	< 984 μin.
Water hardness (total/carbonate)	< 1.4 mmol/l / < 0.9 mmol/l (< 140 ppm / < 90 ppm)
Dimensions (WxHxD)	31.8 x 84.7 x 43.0 in.
Total mass	1,036 lb

TECHNICAL PARAMETERS Cooling blower TB 7/FUK/20

Max. volume flow rate	3,426 CFM
Max. total pressure difference	2.32 psi (16 kPa)
Motor output	20 kW
Max. frequency	105 Hz
Hose diameter	6.89 inch
Hose length (Std.)	197 inch
Total mass	288.8 lb
Dimensions (WxHxD)	24.6 x 30.0 x 23.7 in.
Max. sound pressure level	105 dB(A)
Connection box (fixation to wall):	
Mass	22 lb
Dimensions (WxHxD)	11.8 x 11.8 x 9.8 in.
Power supply (variable)	3~ / PE 480 V±5% 60 Hz CEE 63
Recommended fuse protection (Standard)	50 A slow
Max.current consumption at 480 V	38 A



Cooling unit C 59412



Cooling blower TB 7/FUK/20
with frequency converter



Connection box
with main switch (for blower)