

TECHNICAL PARAMETERS Vibration exciter S 59335/*-640

Rated peak force Sine _{pk} /Random _{RMS} ¹ /Shock _{pk} ²	35000/32000/105000 N
Frequency range	5 - 2000 Hz
Main resonance frequency	2000 Hz
Max. displacement Peak-Peak	50.8 mm
Max. velocity Sine/Random/Shock	2.0/1.8/3.0 m/s
Max. acceleration Sine/Random/Shock	70/63/160 g
Suspension stiffness	150 N/mm
Effective moving mass	40.5 kg
Max. payload	610 kg
Total mass with trunnion RIT/AIT/LB*	2350/2700/2250 kg
Magn. stray field std./low degaussing ³	<2/<1 mT
Armature diameter	640 mm
Required compressed air supply (load-dependent)	600-1000 kPa
Interlocks	Temperature, displacement, cooling air, overcurrent, compressed air

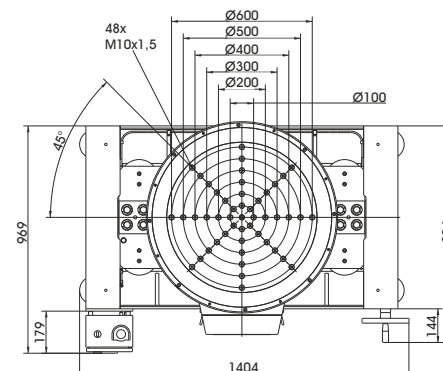
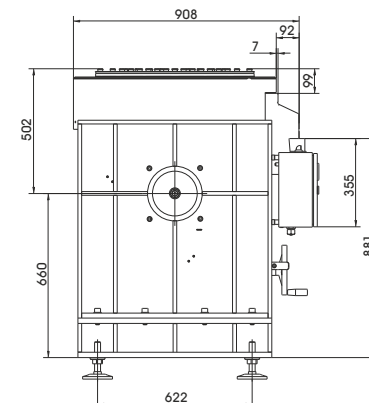
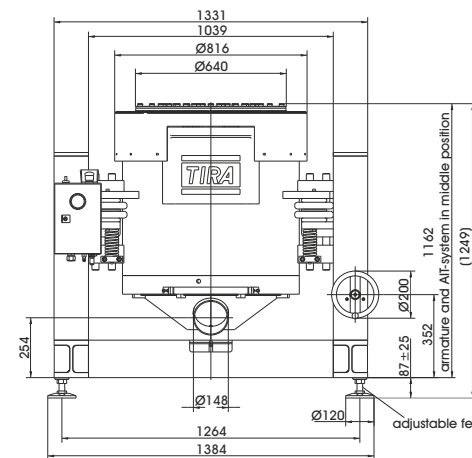

1) Random force according to ISO 5344:2004
 2) Theoretical maximum shock value. Depends on payload, amplifier, shock and shock width
 3) measured at 150 mm above armature inserts
 For long-term tests, the load must be reduced to 80 %. Continuous operation at maximum load can cause damage.
 * RIT, AIT or LB (explanation see TIRA selection guide page 7)

SCOPE OF DELIVERY, OPTIONS AND FEATURES OF THE SYSTEM

<p>Scope of delivery: Vibration exciter 35 kN Trunnion mount (AIT, RIT or LB) Power amplifier 37.5 kVA Cooling blower with frequency converter Connection cables (each 10 m) Power cables (each 10 m) for amplifier (CEE 63 connector) and cooling blower (CEE 32 connector) Blower hose ø150 mm (5 m) Compressed-air hose NW 7,2 (Standard) (5 m)</p> <p>Options: Different hole pattern of armature (different pitch diameter and/or thread inserts) at customers request AIT-trunnion mount with integrated vibration isolation RIT-trunnion mount LB-frame</p>	<p>Options: Low degaussing kit to further reduce stray magnetic field Squeak&Rattle (Silent operation without blower) Wheels&Rails (incl. 3m rails) Airglide-option (Shaker movable on air cushions) Thermobarrier (-40°C to +140°C) Chamber leadthrough Climatic chamber support kit Remote control (Software) ASM-Mode (Auto Shutdown Manager) Silencer for cooling blower (Noise reduction 9 - 15 dB(A)) Acoustic enclosure for cooling blower (Noise reduction 5 - 23 dB(A)) Water-cooled acoustic enclosure for cooling blower (Noise reduction 30 dB(A)) Cable extension Factory acceptance test</p>	<p>Options: TIRA EMS Energy Management System Operation with temperature-controlled cooling blower (and optional with variable field strength)</p> <p>Features: Vibration isolation < 3 Hz (AIT) < 6 Hz (RIT;LB) Coarse filter unit Fully automatic pneumatic load compensation AIT fixable Automatic centering of the AIT-System and the armature Degauss kit to reduce stray magnetic field Made in Germany Servicehotline</p>
---	--	--

TECHNICAL PARAMETERS Amplifier A 3 08 11 063

Output power _{RMS}	37500 VA
Frequency range	DC - 5 kHz
Voltage _{RMS} , max.	212 V
Current _{RMS} , max.	300 A
Signal input voltage _{pk}	± 10 V
Total Harmonic Distortion (at 70A _{RMS} , 200 Hz)	< 0.2 %
Signal to noise ratio	> 80 dB
Field voltage	105 V
Field current	75 A
Total mass	640 kg
Dimensions (WxHxD)	600 x 2200 x 800 mm
Power supply (Standard)	3~ / N / PE 400 V±5% 50 Hz, CEE 63
Recommended fuse protection (Standard)	63 A slow
Max. power consumption at 400 V	32 kVA
Interlocks:	Overload, Temperature, Displacement, Cooling air, Compressed air, Phase monitoring, Emergency stop

Features:
 Field supply integrated
 Mains switch and integrated line filter
 Lo-Field/Hi-Field (Energy-saving mode)
 Field voltage/Field current variable according to customer spec.
 4 Sigma peak current
 Color Touch Screen

TECHNICAL PARAMETERS Cooling blower TB 7/FUK/11

Max. volume flow rate	1920 m³/h
Max. total pressure difference	16 kPa
Motor output	11 kW
Max. frequency	105 Hz
Hose diameter	150 mm
Hose length (Std.)	5 m
Total mass	113 kg
Dimensions (WxHxD)	625 x 775 x 602 mm
Max. sound pressure level	102 dB(A)

Switch box (fixation to wall):
 Mass: 10 kg
 Dimensions (WxHxD): 300 x 300 x 250 mm
 Power supply (variable): 3~ / PE 400 V±5% 50 Hz, CEE 32
 Recommended fuse protection (Standard): 32 A slow
 Max. current consumption at 400 V: 25 A

Options:
 Silencer TB 7/FUK-SI (Noise reduction 9 - 15 dB(A))
 Dimensions (LxD): 1120 x 280 mm
 Mass: 9.2 kg
 Acoustic enclosure TB 7/FUK-AE (Noise reduction 5 - 23 dB(A))
 Dimensions (WxHxD): 1250 x 1393 x 1470 mm
 Mass: 103 kg
 Water-cooled acoustic enclosure WWT (Noise reduction 30 dB(A))
 Dimensions (WxHxD): 1500 x 2080 x 1200 mm
 Mass: 800 kg
 Hose length according to customers request (up to 10 m)



Frequency converter (enclosure)



Cooling blower TB 7/FUK/11



Silencer TB 7/FUK-SI (optional)



Acoustic enclosure TB 7/FUK-AE (optional)